

EFHD FUEL FILTERS

EFHD-9010W

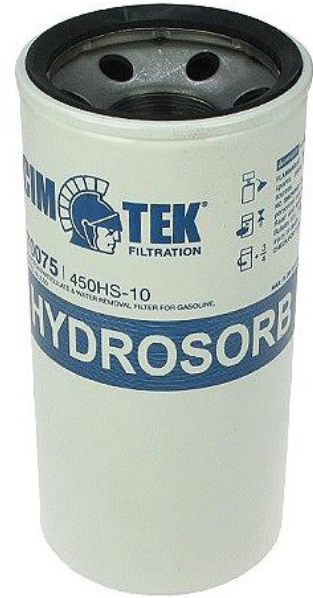
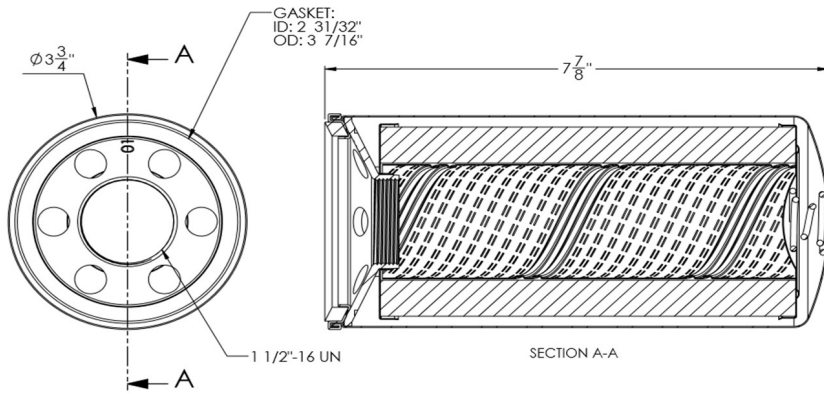

MADE IN USA

DESIGNED TO MOUNT ON LARGE OVERHEAD STORAGE TANKS OR PUMPS

Specifications

| | |
|---------------------------|---------------|
| Maximum Working Pressure: | 50 psi |
| Flow Range: | 94 lpm |
| Maximum Diff. Pressure: | 25 psid |
| Media | 10μ Hydrosorb |

EFHD-9010W

- 90LPM
- 10 micron water block
- Element number 70075
- 50 PSI max pressure
- Replacement element for EFHD-9010W-25
- Use with diesel, petrol, ethanol and methanal blends up to 10%. Hydrosorb.

Reference Performance Values

| | |
|-------------------------|------------------------|
| B _{8.5} = 2 | B ₄ = 1.22 |
| B _{15.5} = 10 | B ₆ = 1.45 |
| B _{22.8} = 75 | B ₁₄ = 1.85 |
| B _{24.0} = 100 | |
| B _{26.8} = 200 | |

Flow Versus Pressure

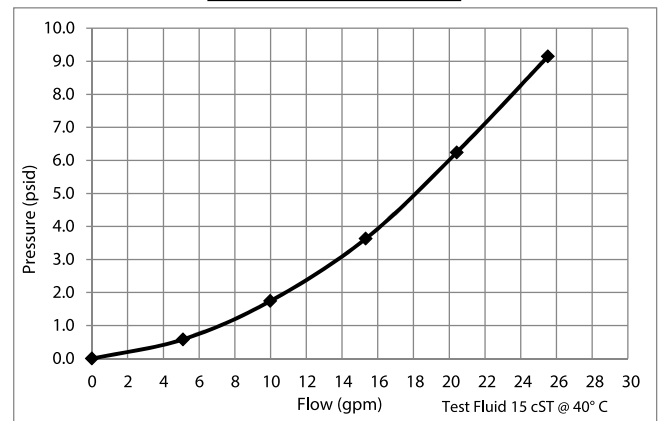

Average Filtration Efficiency

