

EFHD FUEL FILTERS

EFHD-1502W

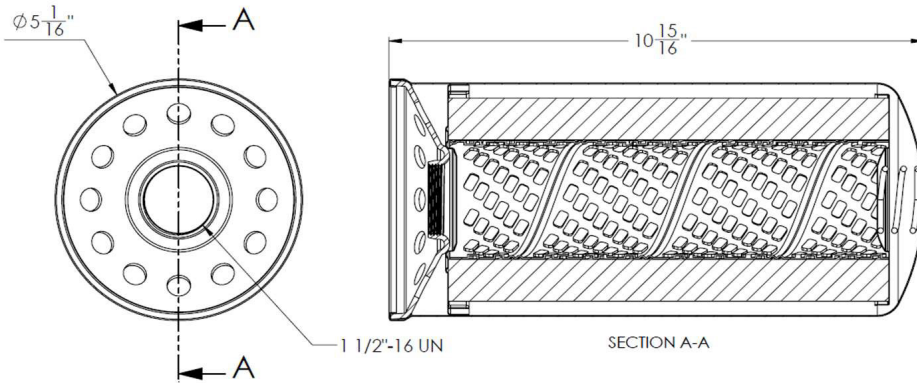

MADE IN USA

DESIGNED TO MOUNT ON LARGE OVERHEAD STORAGE TANKS OR PUMPS

Specifications

Maximum Working Pressure:	50 psi
Flow Range:	150 lpm
Maximum Diff. Pressure:	25 psid
Media	2 μ Hydroglass

EFHD-1502W

- 2 micron Cimtek water absorbing element
- Element number: 70037
- 50 PSI
- 151 LPM
- Use with Diesel, petrol, ULSD and biodiesel use. Hydroglass.

Reference Performance Values

$B_{<4} = 2$	$B_4 = 5.91$
$B_{4.5} = 10$	$B_6 = 40.8$
$B_{6.6} = 75$	$B_{14} = 14963$
$B_{6.8} = 100$	
$B_{7.5} = 200$	

Flow Versus Pressure (ISO 3968)

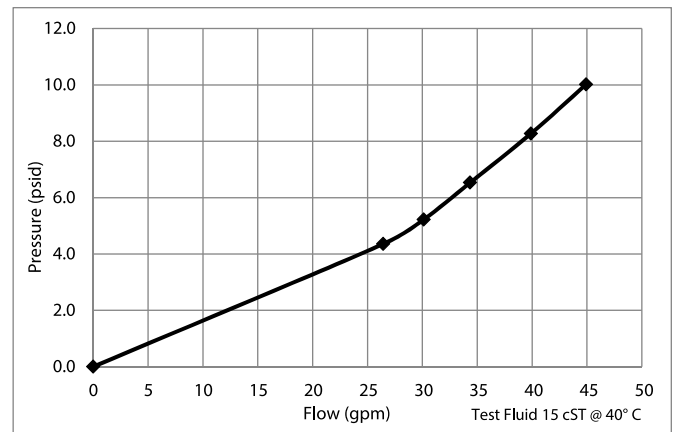

Average Filtration Efficiency (ISO 16889)

