

# EFHD FUEL FILTERS

## EFHD-15010W

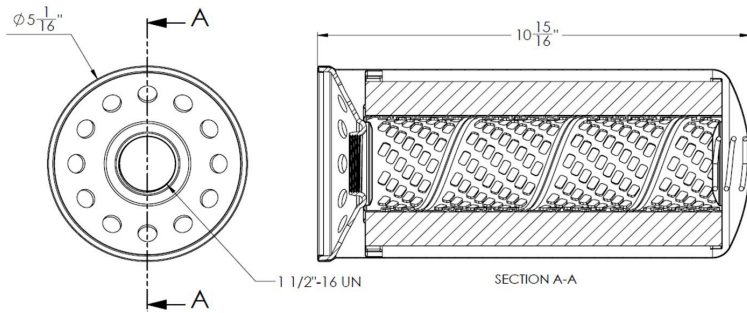

**MADE IN USA**

**DESIGNED TO MOUNT ON LARGE OVERHEAD STORAGE TANKS OR PUMPS**

### Specifications

Maximum Working Pressure:	50 psi / 3.4 bar
Flow Range:	150 LPM
Maximum Diff. Pressure:	25 psid / 1.7 bar
Media	Hydrosorb

### EFHD-15010W

- Removes particulates like dirt, dust, & rust
- For use with Diesel, Gasoline, or ULSD (Ultra Low Sulfur Diesel) fuels
- Detects water in fuel...Guaranteed!
- Element # 70063

### Reference Performance Values

$B_{5.1} = 2$	$B_4 = 1.71$
$B_{>30} = 10$	$B_6 = 2.28$
$B_{>30} = 75$	$B_{14} = 5.26$
$B_{>30} = 100$	
$B_{>30} = 200$	

Retention Capacity - 15.5g

Flow Versus Pressure (ISO 3968)

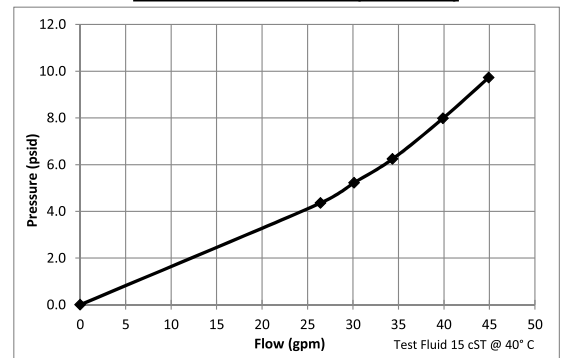

Average Filtration Efficiency (ISO 16889)

