

EFHD FUEL FILTERS

EFHD-15010

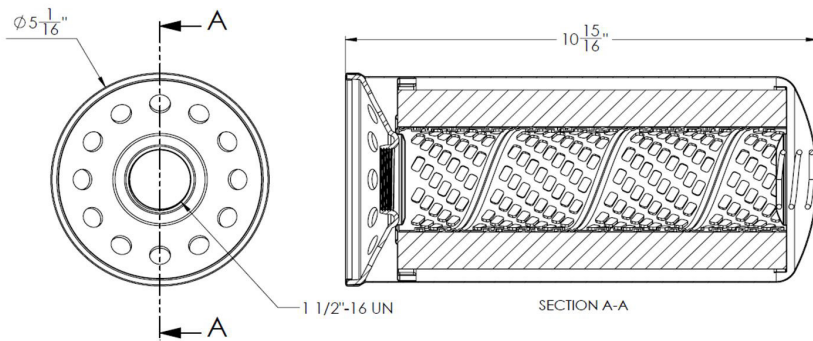

MADE IN USA

DESIGNED TO MOUNT ON LARGE OVERHEAD STORAGE TANKS OR PUMPS

Specifications

Maximum Working Pressure:	50 psi
Flow Range:	150 LPM
Maximum Diff. Pressure:	25 psid
Media	10 μ Cellulose

EFHD-15010

- Removes particulates like dirt, dust, & rust
- For use with diesel, ULSD, gasoline, ethanol blends up to 15%, and bio-diesel blends up to 15%
- Pre-Lubed gaskets
- Element # 70019

Reference Performance Values

$B_{5.1} = 2$	$B_4 = 1.71$
$B_{>30} = 10$	$B_6 = 2.28$
$B_{>30} = 75$	$B_{14} = 5.26$
$B_{>30} = 100$	
$B_{>30} = 200$	

Flow Versus Pressure

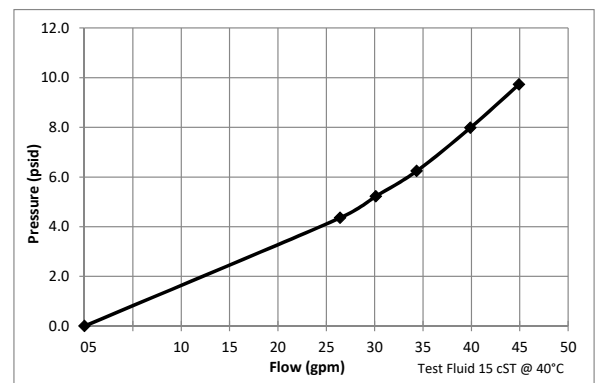

Average Filtration Efficiency

