

# FUEL FILTER 400-10PD

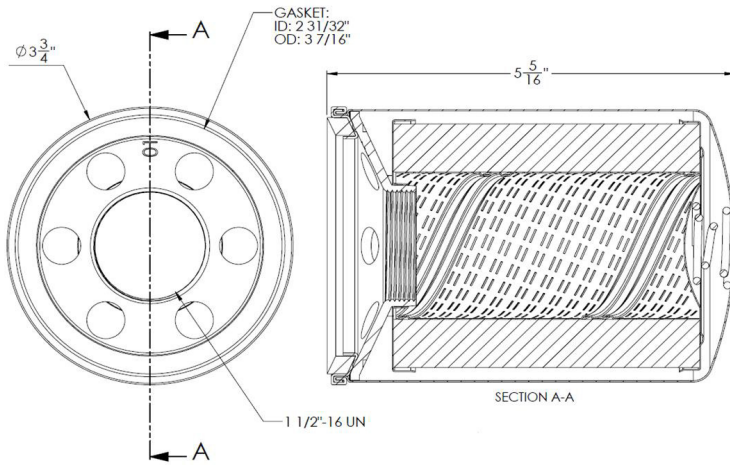

MADE IN USA

DESIGNED FOR FUEL DISPENSERS & COMMERCIAL FUELING PUMPS

## Specifications

Maximum Working Pressure:	50 psi
Flow Range:	94 lpm
Maximum Diff. Pressure:	25 psid
Media	10 $\mu$ Cellulose

## 400-10PD

- 400 series Cimtek Particulate 10 micron dispenser element.
- Element #70015.
- 50 PSI max.
- 94 LPM max flow.
- Petrol, diesel, biodiesel, ULSD Particulate

## Reference Performance Values

$B_{6.3} = 2$	$B_4 = 1.42$
$B_{13.1} = 10$	$B_6 = 1.91$
$B_{20.7} = 75$	$B_{14} = 12.4$
$B_{21.6} = 100$	
$B_{23.7} = 200$	

## Flow Versus Pressure

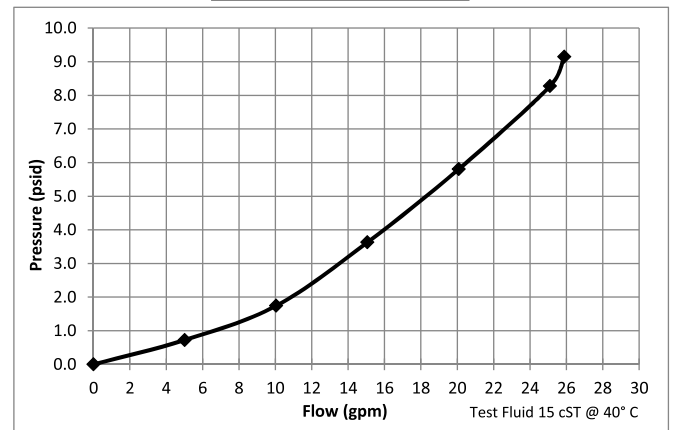

## Average Filtration Efficiency

