

# 200S FUEL FILTERS 200S-6710W

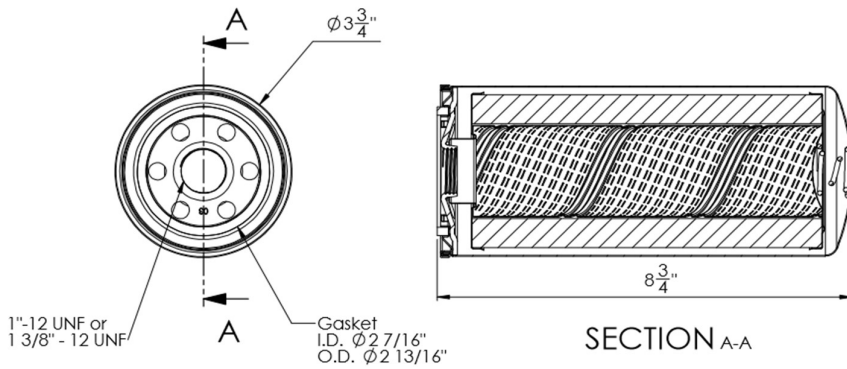

**MADE IN USA**

**DESIGNED TO MOUNT ON LARGE OVERHEAD STORAGE TANKS OR PUMPS**

#### Specifications

Maximum Working Pressure:	50 psi
Flow Range:	94 lpm
Maximum Diff. Pressure:	25 psid
Media	10 $\mu$ Hydrosorb

#### 200S-6710W

- Element number: 70062
- 10 micron Hydrasorb water and sediment absorption element.
- 94LPM
- 50 PSI max
- Diesel, petrol, ULSD, ethanol blends up to 15%. Hydrosorb

#### Reference Performance Values

$B_{7.3} = 2$	$B_4 = 1.2$
$B_{13.9} = 10$	$B_6 = 1.5$
$B_{19.8} = 75$	$B_{14} = 10.3$
$B_{20.8} = 100$	
$B_{23.3} = 200$	

Flow Versus Pressure (ISO 3968)

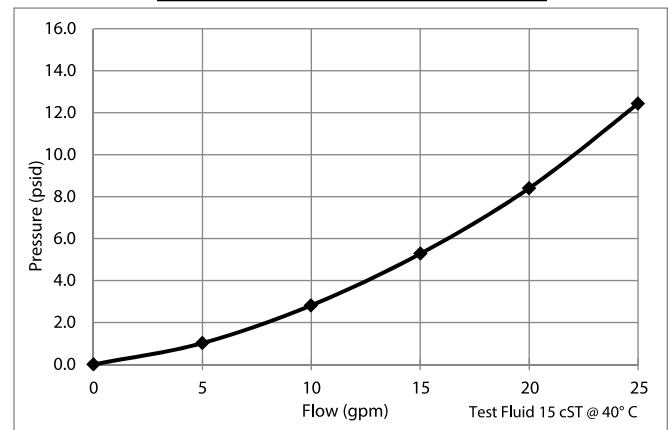

Average Filtration Efficiency (ISO 16889)

