

200S FUEL FILTERS 200S-6710

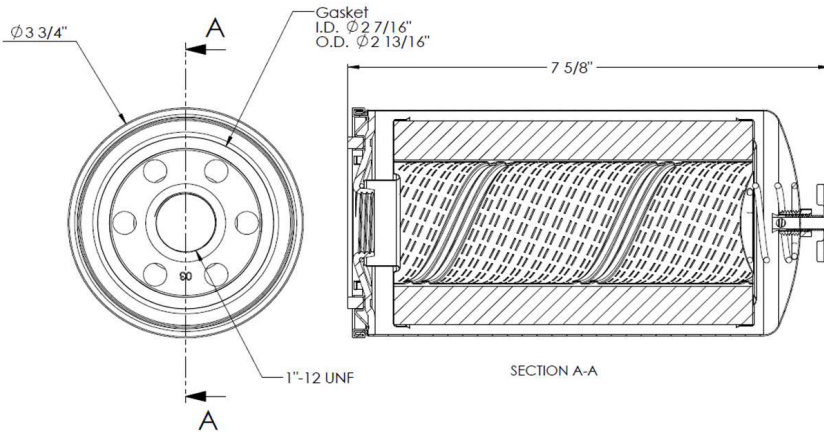

MADE IN USA

DESIGNED TO MOUNT ON LARGE OVERHEAD STORAGE TANKS OR PUMPS

Specifications

Maximum Working Pressure:	50 psi
Flow Range:	67 lpm
Maximum Diff. Pressure:	25 psid
Media	10µ Cellulose

200S-6710

- Replacement element for 200S filters.
- 10 micron. Element #200S-CE.
- 50 PSI max.
- 67 LPM max flow.
- Diesel, petrol, ULSD, biodiesel. Particulate

Average Filtration Efficiency

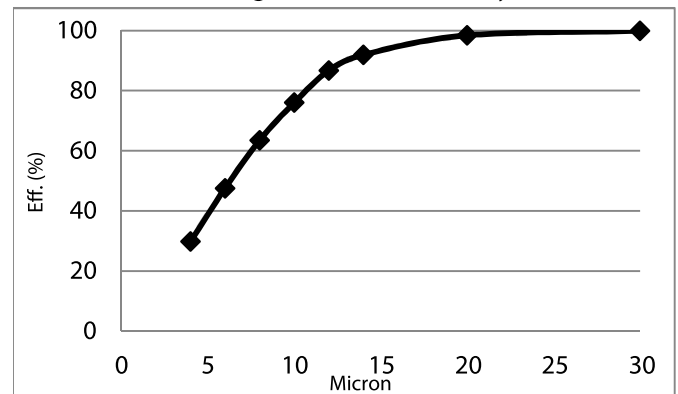

Reference Performance Values

$B_{6.3} = 2$	$B_4 = 1.42$
$B_{13.1} = 10$	$B_6 = 1.91$
$B_{20.7} = 75$	$B_{14} = 12.4$
$B_{21.6} = 100$	
$B_{23.7} = 200$	