

EQUIPCO HOSE REEL

“ Water, Fuel dispensing,
Fire protection, etc. ”



EDH32L

Manual Rewind Hose Reel

Design & Structure

- Heavy duty steel construction reels designed for long lengths of hose
- Permanent direct crank rewind 3:1 ratio
- Roller guides are option (Specify roller position when ordering.)
- Brake System: cam-lock drag brake or spring actuated pin lock (Supplied with spring actuated pin lock as standard)
- Full flow shaft and swivel
- Standard inlet 90° balanced pressure swivel joint (NBR Packing)
- All (Outlet & inlet) connection threads are female BSP (Other threads can be furnished when you requested)
- All materials are carbon steel as standard (Stainless, Aluminum and other materials are available when you requested)

Painting : Powder Coat.

Type of Bevel Gear crank rewind is options (Pinion brake as standard)

All HD series reels are supplied without hose, hose assemblies will be quoted as you requested.

Other specifications are available.



EDH40L

Item Code	Size (Inch)	Length (Mtr)	Max Pressure	Max Temperature	Rewind Type
EQH32L	1 1/4 "	30Mtr	1000psi/ 69bar	100°C	Manual
EQH40L	1 1/2 "				

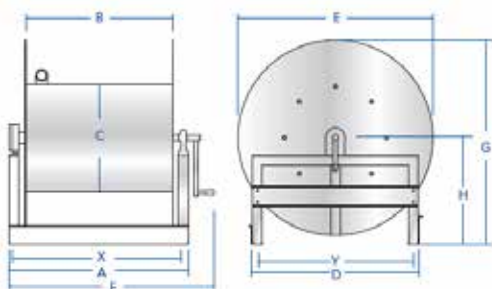

Item Code	HOSE CAPACITY(mm)			REEL DIMENSIONS(mm)									
	I.D	O.D	Length	A	B	C	D	E	F	G	H	X	Y
EQH32L	32	43.9	30	510	350	300	590	650	770	700	375	470	490
EQH40L	38	50.8	30	560	400	300	590	650	840	700	375	520	490

EQUIPCO HOSE REEL

Manual Rewind Hose Reel

“ For Air, Water, Fuel
Dispensing Etc ”

Design & Structure

- Lightweight steel construction , compact design and versatile usage.
- Dual frame ,guide plate & ball bearing support.
- Permanent direct crank rewind .
- Roller guides is option.(Specify roller position when ordering.)
- Brake System: cam-lock drag brake or spring actuated pin lock(Supplied with spring actuated pin lock as standard)
- Full flow shaft and swivel.
- Standard inlet 90° balanced pressure swivel joint(NBR Packing)
- All(Outlet & inlet) connection threads are female BSP(Other threads can be furnished when you requested)
- All materials are carbon steel as standard(Stainless, Aluminum and other materials are available when you requested)
- HT series reels are supplied without hose, hose assemblies will be quoted as you requested
- Other specifications are available.

Painting : Powder Coat.



EQH25L

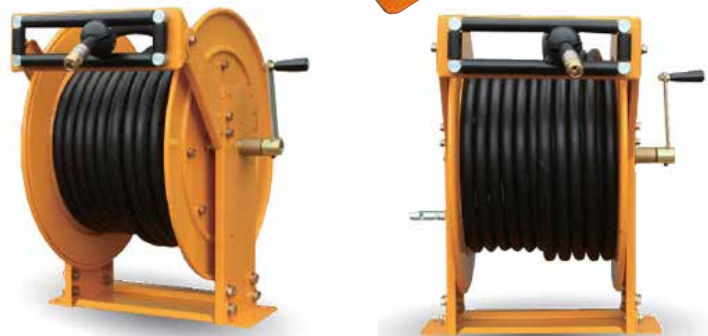

Item Code	Size (Inch)	Length (Mtr)	Max Pressure	Max Temperature	Rewind Type
EQH25L	1 "	20Mtr	1000psi/ 69bar	100°C	Manual

Item Code	HOSE CAPACITY(mm)			REEL DIMENSIONS(mm)									
	I.D	O.D	Length	A	B	C	D	E	F	G	H	X	Y
EQH25L	25	35.6	20	300	240	250	200	500	470	540	290	350	160

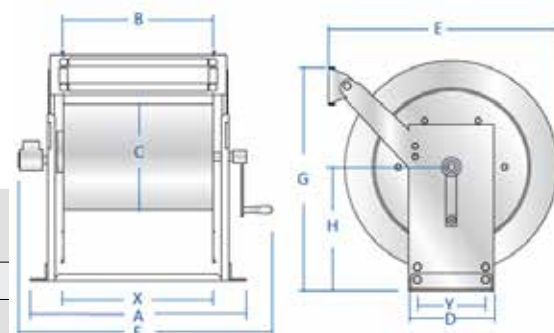

EQUIPCO HOSE REEL

Spring Rewind Hose Reel

“ For Air,
Water, Hydraulic,
Lubrication, Fuel
dispensing etc ”

Design & Structure

- Heavy duty steel construction & Protect pipe for reel drum.
- All bolted assembly without welding
- Dual frame ,guide plate & ball bearing support.
- Special heat-treatment spring & non-corrosive ratchet.
- 4-way roller assembly.
- Full flow shaft and swivel.
- Standard inlet 90° balanced pressure swivel joint (NBR Packing)
- All(Outlet & inlet) connection threads are female BSP(Other threads can be furnished when you request)
- All materials are carbon steel as standard(Stainless, Aluminum and other materials are available when you request)

Painting : Powder Coat.



Item Code	Size (Inch)	Length (Mtr)	Max Pressure	Max Temperature	Rewind Type
EQS25L	1 "	20Mtr	1000psi/69bar	100°C	Spring
EQS32L	1 1/4"				
EQS40L	1 1/2"				

Item Code	HOSE CAPACITY(mm)			REEL DIMENSIONS(mm)									
	I.D	O.D	Length	A	B	C	D	E	F	G	H	X	Y
EQS25L	25	35.6	20	380	240	250	440	500	510	545	290	340	310
EQS32L	32	43	20	370	230	260	500	600	500	660	360	325	350
EQS40L	40	50.6	20	42	280	260	500	640	550	700	380	375	350

